

Instruction Manual

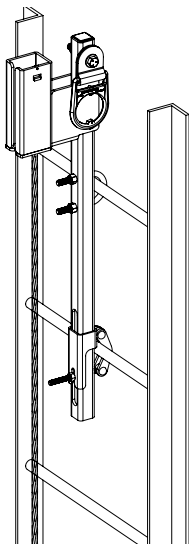

⚠ User shall read, understand, and follow manufacturer's instructions before using this or any fall protection equipment. FAILURE TO FOLLOW MANUFACTURER'S INSTRUCTIONS MAY RESULT IN SERIOUS INJURY OR DEATH.

A copy of the manufacturer's instructions shall be provided to all users and shall be retained for the safe use of the system.

2	Safety Information
3	Applicable Safety Standards
3	Intended Use
3	Worker Classifications
3	Permitted Worker Capacity Range
4	Product Specific Applications
4	Limitations
4	Compatibility
5	Inspection
6	Components and Materials
7	Part Descriptions
8	Installation and Use
12	Maintenance, Cleaning, and Storage
12	Diagrams
13	Labels
15	Inspection Log

Safety Information

▲ WARNING! Failure to understand and comply with safety regulations may result in serious injury or death. Regulations included herein are not all-inclusive, are for reference only, and are not intended to replace a Competent Person's judgment or knowledge of federal or state standards.

Always read and understand this Instruction Manual before use. It should be used as part of an employee training program as required by OSHA or any applicable state agency. This and any other included instructions for other fall protection equipment must be made available to equipment users. The user must understand how to safely and properly use this product as a component of a complete personal fall arrest system, including other fall protection equipment.

Do not misuse equipment.

NEVER attempt to repair, adjust, or alter Cable Climbing System or Sleeve.

Workplace conditions, including, but not limited to, flame, corrosive chemicals, electrical shock, sharp objects, machinery, abrasive substances, weather conditions, and uneven surfaces, must be assessed by a Competent Person before fall protection equipment is selected.

The analysis of the workplace must anticipate where users will be performing their duties, the routes they will take to reach their work, and the potential and existing fall hazards they may be exposed to. Fall protection equipment must be chosen by a Competent Person and must account for all potential hazardous workplace conditions. All fall protection equipment should be purchased new and in an unused condition.

Fall protection systems must be selected and installed under the supervision of a Competent Person, and used in a compliant manner. Fall protection systems must be designed in a manner compliant with all local, state, and federal safety regulations. Forces applied to anchors must be calculated by a Competent Person.

Harnesses and connectors selected must be compliant with manufacturer's instructions, and must be of compatible size and configuration. Snap

hooks, carabiners, and other connectors must be selected and applied in a compatible fashion. All risk of disengagement must be eliminated. All snap hooks and carabiners must be self-locking, self-closing, and must never be connected to each other.

A pre-planned rescue procedure in the case of a fall is required. The rescue plan must be project-specific. The rescue plan must allow for employees to rescue themselves, or provide an alternative means for their prompt rescue. Store rescue equipment in an easily accessible and clearly marked area.

Training of Authorized Persons to correctly erect, disassemble, inspect, maintain, store, and use fall protection equipment must be provided by a Competent Person. Training must include the ability to recognize fall hazards, minimize the likelihood of fall hazards, and the correct use of personal fall protection systems.

NEVER use fall protection equipment of any kind to hang, lift, support, or hoist tools or equipment, unless explicitly certified for such use.

Equipment that fails inspection or that has been subjected to forces of fall arrest must immediately be removed from service. All product that has been removed from service due to failed inspection or fall arrest must be clearly and permanently marked "DO NOT USE". Equipment must then be destroyed and rendered unusable prior to disposal to eliminate the potential for reuse. Equipment must be disposed in accordance with all applicable local, state, and federal requirements.

Age, fitness, and health conditions can seriously affect the user should a fall occur. Consult a doctor if there is any reason to doubt a user's ability to withstand and safely absorb fall arrest forces or perform set-up of equipment. Pregnant women and minors must not use this equipment.

Serious injury or death may still occur even if fall protection equipment functions correctly. Always follow your pre-planned rescue procedure.

Sustained post-fall suspension may result in serious injury or death. Use Suspension Trauma Relief Straps to reduce the effects of suspension trauma.

Applicable Safety Standards

Meets or exceeds:

- ANSI/ASSE Z359.16
- OSHA 1910.29
- OSHA 1926.1053

IMPORTANT: Applicable standards and regulations depend on the type of work to be performed and may include additional applicable regulations in some states. Consult local authorities having jurisdiction for more information on fall protection systems and associated fall protection components.

Intended Use

This equipment is designed to be used as a component of a personal fall protection system (PFAS). **USE OF THIS EQUIPMENT IN A MANNER THAT IS NOT EXPRESSLY DESCRIBED IN THESE MANUFACTURER INSTRUCTIONS MAY RESULT IN SERIOUS INJURY OR DEATH.**

NOT FOR USE IN WORK POSITIONING APPLICATIONS. ALWAYS USE A SEPARATE WORK POSITIONING SYSTEM.

WHEN CONNECTING TO OR DISCONNECTING FROM THE CABLE CLIMBING SYSTEM, ALWAYS MAKE SURE TO USE A SUPPLEMENTAL FALL ARREST SYSTEM, OR ENSURE THAT NO POSSIBILITY OF BEING EXPOSED TO A FALL HAZARD EXISTS.

Cable climbing system shall be used with ANSI Z359.11 compliant full body harnesses only. Harness must include a Sternal D-ring and must be in good condition and approved for use in cable climbing applications. Always refer to full body harness manufacturer's instructions for suitability for use in cable climbing applications.

Worker Classifications

- **Qualified Person:** A person with an accredited degree or certification, and with extensive experience or sufficient professional standing, who is considered proficient in planning/reviewing the conformity of fall protection and rescue systems.
 - **Competent Person:** A highly trained and experienced person who is ASSIGNED BY THE EMPLOYER to be responsible for all elements of a fall safety program, including, but not limited to, its regulation, management, and application. A person who is proficient in identifying existing and predictable fall hazards, and who has the authority to stop work in order to eliminate hazards.
 - **Authorized Person:** A person who is assigned by their employer to work around or be subject to potential existing fall hazards.
-

Permitted Weight Capacity Range

- ANSI: 130-310 lb (59-140 kg)
- OSHA: 100-310 lb (46-140 kg)

Always defer to applicable connecting device to determine permitted worker weight capacity range for complete system.

Note: Capacity is the combined user weight including all clothing, tools, and equipment.

▲ WARNING! MAXIMUM 2 USERS PER Cable Climbing System.

Minimum spacing between users must be 20 ft (6 m).

Product Specific Applications



Ladder Climbing: The Cable Climbing System may be used to support a **MAXIMUM 2 Personal Fall Arrest System (PFAS)** for use in Fall Arrest applications.

Structure must withstand loads applied in the directions permitted by the system of at least 3,600 lb (16 kN). Maximum permitted free fall is 2 ft (0,6 m).

D-ring: **Sternal**



Fall Arrest (Anchorage Connector Only): May be used to support a **MAXIMUM 1 Personal Fall Arrest System (PFAS)** for use in Fall Arrest applications.

Structure must withstand loads applied in the directions permitted by the system of at least 3,600 lb (16 kN). Maximum permitted free fall is 6 ft (1,8m), or up to 12 ft (3,6 m) if used in combination with equipment explicitly certified for such use.

D-rings: **Dorsal**

Limitations

Fall Clearance: There must be sufficient clearance below the work surface to arrest a fall before the user strikes the ground or an obstruction. When calculating fall clearance, account for a **MINIMUM 2 ft (0,6 m)** safety factor, deceleration distance, user height, length of connecting devices, harness stretch, free fall, and all other applicable factors.

See **Diagram A** on page 12.

Swing Falls: Prior to installation or use, make considerations for eliminating or minimizing all swing fall hazards. Swing falls occur when the anchor is not directly above the location where a fall occurs. Always work as close to in-line with the anchor point as possible. Swing falls significantly increase the likelihood of serious injury or death in the event of a fall.

Compatibility

When making connections, eliminate all possibility of roll-out. Roll-out occurs when interference between a connector and the attachment point causes the connector gate to unintentionally open and release.

All connections must be selected and deemed compatible with the harness by a Competent Person.

All connector gates must be self-closing, self-locking, and withstand a minimum load of 3,600 lb (16 kN).

See **Diagram B** Page 13

Compatible Cable Climbing Sleeve: Guardian part number 25034

▲ WARNING! Use only with compatible Guardian cable climbing sleeve and 3/8" diameter 1x7 Guardian galvanized steel cable.

Maximum Arrest Force (MAF): 1,800 lb (8 kN)

Average Arrest Force (AAF): 1,350 lb (6 kN)

Inspection

Prior to EACH use, inspect Cable Climbing System for deficiencies, including, but not limited to, corrosion, deformation, pits, burrs, rough surfaces, sharp edges, cracking, rust, paint build-up, excessive heating, alteration, and missing or illegible labels. **IMMEDIATELY remove Cable Climbing System from service if defects or damage are found, or if exposed to forces of fall arrest.**

Ensure that applicable work area is free of all damage, including, but not limited to, debris, rot, rust, decay, cracking, and hazardous materials. Ensure that work area will support the application-specific minimum loads set forth in this manual. Work area **MUST** be stable.

At least every 12 months, a Competent Person (CP) other than user must inspect Cable Climbing System

Inspections MUST be recorded in inspection log (see page 15). The CP must sign their initials in the box corresponding to the month and year the inspection took place.

During inspection, consider all applications and hazards the Cable Climbing System has been subjected to.

Product lifetime is indefinite as long as it passes pre-use and CP inspections.

The inspection log must be specific to one Cable Climbing System. Separate inspection logs must be used for each Cable Climbing System. All inspection records must be made visible and available to all users at all times.

Cable and Shock Absorber Inspection:

Check for deformation or compression of the shock absorbing element at the top of cable, as well as any kinks in the cable, which may indicate the system has been subjected to fall forces.

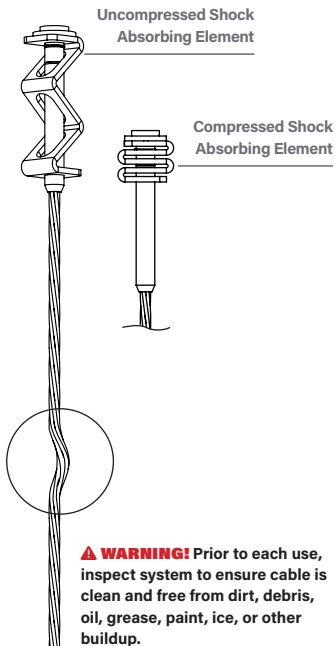

Components

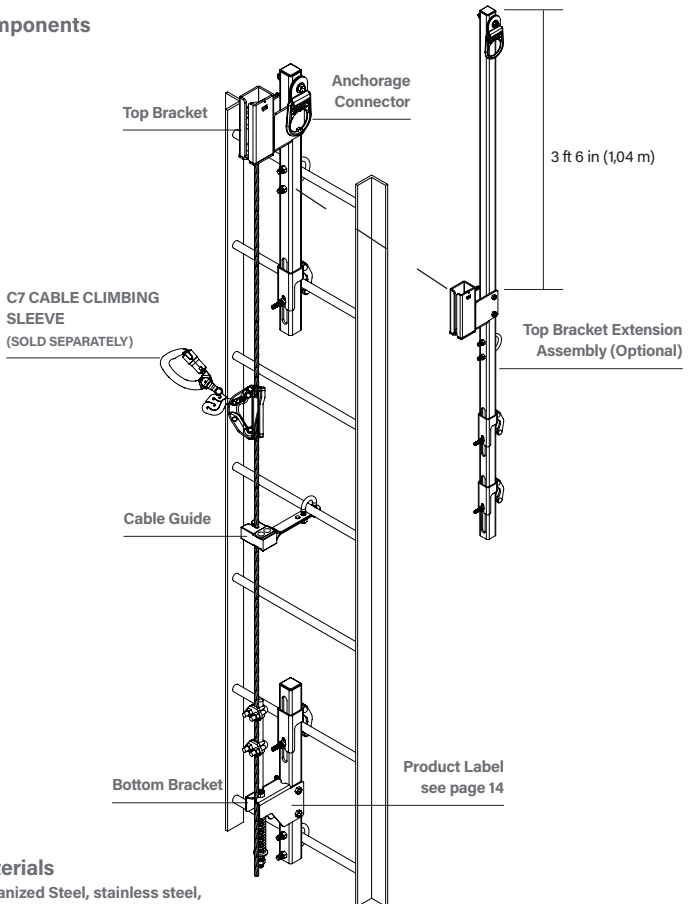

Materials

Galvanized Steel, stainless steel,
rubber



Part #	
Galvanized Steel	Description
1400305	20 ft (6 m) Cable Climbing System, Top and Bottom Brackets
1400306	30 ft (9 m) Cable Climbing System, Top and Bottom Brackets, 1 Cable Guide
1400307	40 ft (12 m) Cable Climbing System, Top and Bottom Brackets, 1 Cable Guide
1400308	50 ft (15 m) Cable Climbing System, Top and Bottom Brackets, 2 Cable Guides
1400309	60 ft (18 m) Cable Climbing System, Top and Bottom Brackets, 2 Cable Guides
1400310	70 ft (21,3 m) Cable Climbing System, Top and Bottom Brackets, 3 Cable Guides
1400311	80 ft (24,3 m) Cable Climbing System, Top and Bottom Brackets, 3 Cable Guides
1400312	90 ft (27,4 m) Cable Climbing System, Top and Bottom Brackets, 4 Cable Guides
1400313	100 ft (30,4 m) Cable Climbing System, Top and Bottom Brackets, 4 Cable Guides
1400314	125 ft (38 m) Cable Climbing System, Top and Bottom Brackets, 6 Cable Guides
1400315	150 ft (46 m) Cable Climbing System, Top and Bottom Brackets, 7 Cable Guides
1400316	175 ft (53,3 m) Cable Climbing System, Top and Bottom Brackets, 8 Cable Guides
1400317	200 ft (61 m) Cable Climbing System, Top and Bottom Brackets, 9 Cable Guides
1400318	225 ft (68,5 m) Cable Climbing System, Top and Bottom Brackets, 11 Cable Guides
1400319	250 ft (76 m) Cable Climbing System, Top and Bottom Brackets, 12 Cable Guides
1400320	275 ft (84 m) Cable Climbing System, Top and Bottom Brackets, 13 Cable Guides
1400321	300 ft (91,4 m) Cable Climbing System, Top and Bottom Brackets, 14 Cable Guides
1400143	Top Bracket Extension Assembly
1400345	Cable Guide Assembly
25034	C7 Cable Climbing Sleeve

Installation and Use

⚠ WARNING! Cable Climbing System shall only be attached to approved fixed ladder structures using the fasteners supplied at time of shipment. Installation on substrates other than fixed ladders or those using alternate fastening methods such as welding or strapping are not permitted.

⚠ WARNING! Cable Climbing System may be attached to fixed ladder systems that utilize hollow rungs, provided they have been reinforced provided the ladder meets the structural requirements of the system and has been approved by a Qualified Person prior to use.

⚠ WARNING! Always utilize a backup fall protection system if exposed to the risk of a fall hazard during installation of Cable Climbing System. NEVER connect to a partially installed Cable Climbing System.

⚠ WARNING! Cable Climbing System shall only be used on cable systems that allow free travel without obstructions, including, but not limited to: blocking hazards, gaps, slippery or loose surfaces, tight/confined spaces, or extreme weather.

⚠ WARNING! May be attached to caged ladder systems provided Cable Climbing System is used as the primary fall arrest system and the ladder cage does not interfere with the normal operation of the Cable Climbing System.

⚠ WARNING! Only attach to sternal D-ring of compatible full body harness. Maximum length of connection between cable and bearing point of harness sternal D-ring shall be 9 in (228 mm). NEVER add additional carabiners or other connectors to increase this distance.

⚠ WARNING! In the event of a fall, immediately remove Cable Climbing System from service.

- Before installation, inventory full system to ensure there are no missing parts. In the event there are missing parts, DO NOT USE and contact Guardian IMMEDIATELY for assistance. DO NOT USE ALTERNATE PARTS OR FASTENERS TO INSTALL CABLE CLIMBING SYSTEM.
- Always wear appropriate protective gear, including eye protection, when installing Cable Climbing System.

Tools Required

- 11/16" Long Socket and Wrench
- 5/8" Long Socket and Wrench
- 9/16" Socket and Wrench
- 1/2" Socket and Wrench
- Torque Wrench

System Rung Compatibility

	Min.	Max.
Rung Spacing	8 in (203 mm)	14 in (356 mm)
Cylindrical Rung	0.5 in (12.7 mm)	1.5 in (38 mm)
Square Rung	0.5 in (12.7 mm)	1.5 in (38 mm)
Diamond Rung	0.5 in (12.7 mm)	1.5 in (38 mm)
Angle Iron	0.5 in (12.7 mm)	1.5 in (38 mm)

Bolt Thread Protrusion

- During installation or subsequent pre-use inspections, in addition to torquing nuts to values specified in this manual, all nuts must be tightened so that a minimum of two (2) complete threads extend beyond the outer face of the nut as shown in image below.

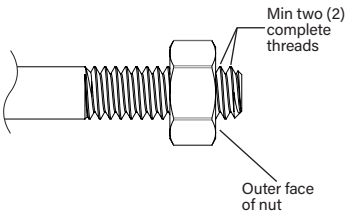

Top Bracket Installation

Step 1

Position Top Bracket in center of climbing side of compatible ladder rung. Install U-bolt from back side of ladder rung through holes in Top Bracket post and install nuts loosely.

Step 2

Slide lower clamp sleeve onto Top Bracket post with slot toward the bottom, hook clamp over ladder rung and guide threaded rod through Top Bracket post and install nut. **Threaded rod must remain within the slot on the lower clamp sleeve (see image below).**

Confirm final position of Top Bracket and torque all nuts with 11/16" wrench or socket to 30-35 ft-lb (40-47 Nm).

Step 3

Seat cable firmly in Top Bracket receptacle.

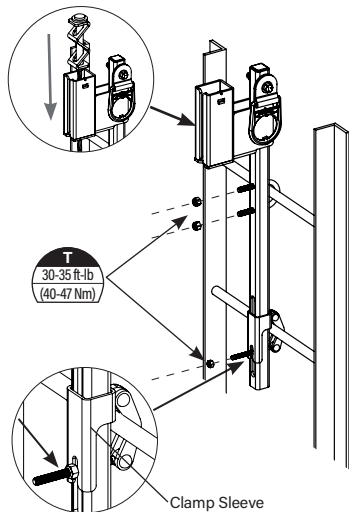

Cable Guide Installation

Step 1

Position Cable Guide bracket in center of ladder rung (bracket may be installed on top of or underneath rung). Install U-bolt over rung and through holes in bracket and install nuts.

Confirm final position of Cable Guide bracket and torque all nuts with 9/16" wrench or socket to 30-35 ft-lb (40-47 Nm).

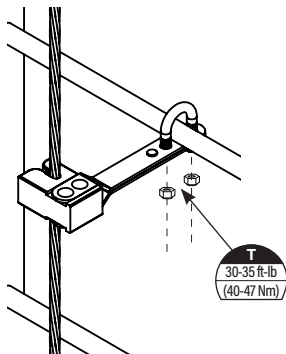

Cable Guide Spacing

Note: Maximum space between cable guides must be 20 ft (6 m) or less.

- For 30, 50, 70, 90, 125, 175, 225, 275 ft (9, 15, 21,3, 27,4, 38, 53,3, 68,5, 84 m) systems, install first Cable Guide 15 ft (4,5 m) from the Bottom Bracket, then at 20 ft (6 m) intervals to Top Bracket.
- For 40, 60, 80, 100, 150, 200, 250, 300 ft (12, 18, 24,3, 30,4, 46, 61, 76, 91,4 m) systems, install all Cable Guides at 20 ft (6 m) intervals.

Bottom Bracket Installation

Step 1

Position Bottom Bracket in center of climbing side of compatible ladder rung. Install U-bolt from back side of ladder rung through holes in Top Bracket post and install nuts loosely.

Step 2

Slide lower clamp sleeve onto Bottom Bracket post with slot toward the bottom, hook clamp over ladder rung and guide threaded rod through Bottom Bracket post and install nut. **Threaded rod must remain within the slot on the lower clamp sleeve (see image below).**

Confirm final position of Bottom Bracket and torque all nuts with 11/16" wrench or socket to 30-35 ft-lb (40-47 Nm).

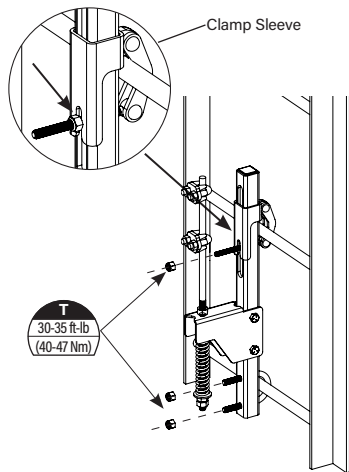

Tensioning the Cable

Step 1

Before tensioning, ensure Tensioning Bar on Bottom Bracket is installed correctly (see image below) and spring on tensioning bar is fully relaxed.

Lower Tensioning and Lock Nuts should be at lowest position on Tensioning Bar, Upper Lock Nut should be at uppermost position possible.

Step 2

While lifting Tensioning Bar to its highest position, secure cable to bar with saddles and nuts provided.

Confirm Tensioning Bar is at highest position and torque cable clamp nuts with 1/2" wrench or socket to 10-15 ft-lb (14-20 Nm).

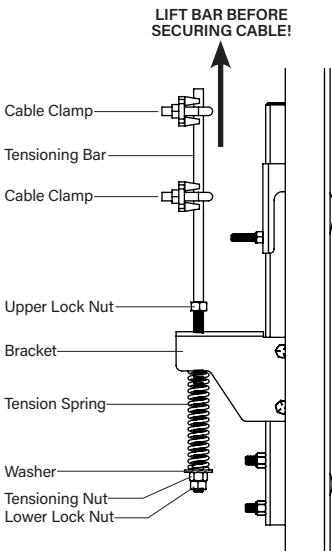

Step 3

Tension cable by tightening Tensioning Nut until it is at least flush with bottom of Bracket (see image below).

Step 4

Confirm final location of Tensioning Nut and secure Tensioning Bar by tightening Upper and Lower Lock Nuts with 5/8" wrench until they make firm contact with Bracket (Upper) or Tensioning Nut (Lower). Confirm Cable Clamp nut torque after tensioning system.

Confirm all other components of the system are installed correctly. System is ready for use.

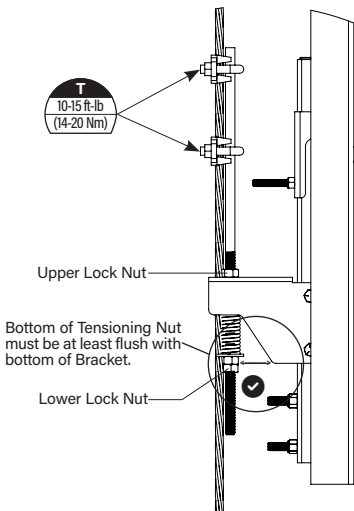

Anchorage Connector Use

▲ WARNING! Anchorage Connector may be used to support a MAXIMUM 1 Personal Fall Arrest System (PFAS) for use in Fall Arrest applications.

▲ WARNING! Never use Cable Climbing System and Fall Arrest Anchorage Connector simultaneously.

▲ WARNING! Never use Fall Arrest Anchorage Connector for applications where the fall hazard is not directly below the connector. Not for Leading Edge work or applications that could result in side loading or horizontal fall arrest forces. May be used in Travel Restraint applications.

▲ WARNING! Always use a tag line on SRL lifelines to maintain access. Never store SRL lifeline extended such as connected to a lower rung of fixed ladder systems.

▲ WARNING! In the event of a fall, Cable Climbing System MUST be removed from service.

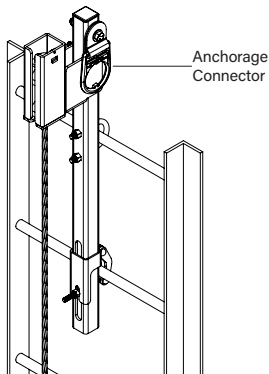

Maintenance, Cleaning, and Storage

Cleaning after use is important for maintaining the safety and longevity of the Cable Climbing System. Remove all dirt, corrosives, and contaminants from the system before and after each use. If a Cable Climbing System cannot be cleaned with plain water, use mild soap and water, then rinse and wipe dry. NEVER clean Cable Climbing System with corrosive substances.

When not in use or during transport, store equipment where it will not be affected by heat, light, excessive moisture, chemicals, or other degrading elements.

Diagram A - Fall Clearance



⚠ WARNING! Eliminate Swing Fall whenever possible! If swing fall exists, always account for additional fall clearance.

Diagram B - Connections

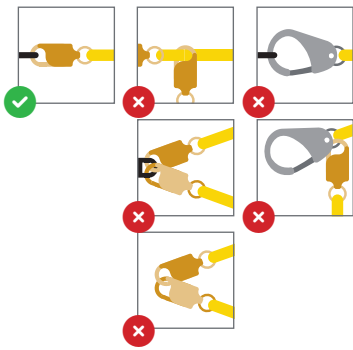



Labels



GUARDIAN[®]

Cable Climbing System

OSHA 1910.29 & 1926.1053 | ANSI Z359.16



Read the Instructions
Vea las Instrucciones | Voir les Instructions

⚠ WARNING Read and follow manufacturer's instructions included at time of shipment. Failure to follow instructions may result in serious injury or death. Use only with compatible Guardian Cable Climbing Sleeve: Part # 25034 and 3/8" (9.5mm) diameter 1x7 galvanized steel cable. Inspect before each use. Competent Person to inspect at least every 12 months. Immediately remove from service if product is subjected to a fall or fails inspection. Never attempt to modify or repair this product.

User Weight Range (including tools and equipment): 100-310 lb (46-140 kg)

Maximum Number of 2 Users

Designed and Tested in USA

Installation Date:

Initials Date

1500272 Rev. A



Part #

Serial #

Lot #

DOM

guardianfall.com

DO NOT REMOVE LABELS

Cable Climbing System

OSHA 1910.29 & 1926.1053 | ANSI Z359.16

Read the Instructions | Vea las Instrucciones | Voir les Instructions

Read and follow manufacturer's instructions included at time of shipment. Failure to follow instructions may result in serious injury or death. Use only with compatible Guardian Cable Climbing Sleeve: Part # 25034 and 3/8" (9.5mm) diameter 1x7 galvanized steel cable. Inspect before each use. Competent Person to inspect at least every 12 months. Immediately remove from service if product is subjected to a fall or fails inspection. Never attempt to modify or repair this product.

User Weight Range (including tools and equipment): 100-310 lb (46-140 kg)

Maximum Number of 2 Users

Designed and Tested in USA

1500272 Rev. A

**USA**

607 East Sam Houston Parkway South
Suite 800
Pasadena, TX 77503
800 466 6385
customer.service@guardianfall.com

UK

New Road, Sheerness
Kent ME12 1PZ
United Kingdom
+44 (0) 1795 580 333
enquiries@guardianfall.com

CANADA

580 Notre Dame Avenue, Unit 16
Sudbury, ON
P3C 5L2
800 466 6385
customer.service@guardianfall.com

WARRANTY: Guardian warrants to Buyer that all products are free from defects in material, workmanship, and design (if a Supplier-responsible design), however this warranty does not cover conditions resulting from normal wear and tear, neglect, abuse, accident or otherwise. Guardian's obligations under this warranty apply for the lifetime of the products and are limited to the replacement of product only. This warranty is not transferable to any other Guardian service and does not apply to product that is resold after having been put into service. No other person, firm, entity, or the like is authorized to assume or assign for Guardian any other liability in connection with the sale or use of Guardian's products. Furthermore, this warranty is void if any product is changed or altered in any way, or if the product is used in a manner other than for which it is intended. There are no implied warranties of merchantability or fitness for a particular purpose, which are specifically disclaimed.

Guardian® and its logo are registered trademarks of Pure Safety Group Inc. dba Guardian Fall in the US and other countries.